INSTALLATION & ASSEMBLY INSTRUCTIONS
Grease Trough and Curb Hinge Assemble For
Models PNU, PDU, USNU, and USDU

RECEIVING AND INSPECTION

Immediately upon receipt of a shipment, carefully inspect for damage and shortage. If any damage and/or shortage is detected or suspected the carrier must be asked to conduct an inspection. The consignee's representative should not accept shipment without a notation on the delivery receipt indicating items not delivered or apparent extent of damage.

When a shipment is opened and damage is found which was not evident externally (concealed damage), it is mandatory that the consignee request an immediate inspection by the carrier. Report damage to the carrier within 15 days. Failure to report damage within the above time limit will cause rejection of a claim.

HANDLING

When handling fans and their accessories, always use equipment and methods that will not cause damage. Fans should be lifted using slings and padding or spreaders to avoid damage.

CAUTION! Always make sure that all lifting and handling equipment and techniques conform to current safety standards.

Avoid lifting fans in a way that will bend or distort fan parts. Never pass slings or timbers through the orifices of fan.

CAUTION! Do not lift by the fan hood. Fans with special coatings or paints must be protected in handling to prevent damage.

STORAGE

Fans are protected against damage during shipment. If they cannot be installed and put into operation immediately upon receipt certain precautions are necessary to prevent deterioration during storage. Responsibility for integrity of fans and accessories during storage must be assumed by the user. The manufacturer will not be responsible for damage during storage. These suggestions are provided solely as a convenience to the user, who shall make his own decision as to whether to use any or all of them.

INDOOR: The ideal storage environment for fans and accessories is indoors, above grade, in a low humidity atmosphere which is sealed to prevent the entry of blowing dust, rain, or snow. Temperatures should be evenly maintained at between 70°F and 105°F (wide

temperature swings may cause condensation and "sweating" of metal parts). Windows should be covered to prevent temperature variations caused by sunlight. Provide thermometers and humidity indicators at several points and maintain the atmosphere at 40% relative humidity, or lower.

It may be necessary to use trays of renewable desiccant or portable dehumidifier to remove moisture from the air in the storage enclosure.

Thermostatically controlled portable heaters (vented to outdoors) may be required to maintain even temperatures inside the enclosure.

CAUTION! Provide fire extinguishers, or fire alarms, or telephone to protect building and equipment against fire damage. Be sure that building and storage practices meet all local, state and federal fire and safety codes.

The following fans or accessories must be stored indoors, in a clean dry atmosphere:

- a. Propeller Wall Fans not in Wall Housings.
- b. Any fan which is protected by a cardboard carton.
- c. Motors dismantled from fans.
- d. Spare wheels or propellers.
- e. The belts, sheaves, bushings and other parts when not mounted on fan.
- f. Boxes, bags or cartons of hardware.
- g. Curbs
- h. Shutters

Remove any accumulations of dirt, water, ice or snow and wipe dry before moving indoor storage. Allow cold parts to reach room temperature to avoid "sweating" of metal parts. Open boxes or cartons. Remove any accumulated moisture; if necessary use portable electric heaters to dry parts and packages. Leave coverings loose to permit air circulation and to permit periodic inspection.

Rotate wheels or propellers by hand to distribute bearing grease over the entire bearing surfaces.

Store at least 3 1/2" off the floor on wood blocks covered with moisture proof paper or polyethylene sheathing. Provide aisles between parts and along all walls, to permit air circulation and space for inspection.

OUTDOOR: Fans designed for outdoor use may be stored outdoors, if absolutely necessary. The storage area should be reasonably level and drained or ditched to prevent accumulation of water. Fencing and lighting for security are desirable. Roads or aisles for portable

cranes and hauling equipment are needed. Consider the use of drift fencing to minimize accumulation of blowing snow or dirt.

The following fans may be stored outdoors, if dry indoor storage space is not available:

- a. Fans intended for outdoor use that are crated in wood.
- b. Wall fans where installed in wall housings.

All fans must be supported on wooden blocks or timbers above water or normal snow levels. Provide enough blocking to prevent settling into soft ground. Fans should be set in place using the directional arrow markings on the crate as a guide.

Locate pieces far enough apart to permit air circulation, sunlight, and space for periodic inspection. Place all parts on their supports so that rain water will run off, or to minimize water accumulation. **Do not** cover parts with plastic film or tarps—these cause condensation of moisture from the air passing through heating and cooling cycles.

Fan wheels and propellers should be blocked to prevent spinning caused by strong winds.

INSPECTION AND MAINTENANCE DURING STORAGE

Inspect fans and accessories at least once per month, while in storage. Log results of inspection and maintenance performed. A typical log entry should include the following:

- a. Date
- b. Inspector's Name
- c. Name of Fan
- d. Location
- e. Condition of Paint or Coating
- f. Is moisture present?
- g. Is dirt accumulated?
- h. Corrective steps taken?

If moisture or dirt accumulations are found on parts, the source should be located and eliminated. Fans should be rotated at each inspection by hand ten to fifteen revolutions to redistribute the motor and bearing lubricant.

If paint deterioration begins, consideration should be given to touch-up or repainting. Fans with special coatings may require special techniques for touch-up or repair.

Machined parts coated with rust preventive should be restored to good condition promptly if signs of rust occur. The most critical items are pulleys, shafts and bearing locking collars. At the first sign of rusting on any of the above parts, remove the original rust preventive coating with petroleum solvent and clean lint-free cloths. Polish any remaining rust from surfaces with crocus cloth or fine emery paper and oil. **Do not** destroy the continuity of the surfaces. Wipe clean with lint-free cloths and recoat surfaces evenly and thoroughly with Tectly 506 (Ashland Oil

Company) or equal. For hard to reach internal surfaces or for occasional use, consider using Tectly 511M Rust Preventive or WD40 or equal.

REMOVING FROM STORAGE

As fans are removed from storage to be installed in their final location, they should be protected and maintained in similar fashion, until the fan equipment goes into operation.

GREASE TROUGH INSTALLATION (Roof Fan)

1. Place grease trough assembly in position on curb as shown in Figure A. The hole in the center of the grease trough top should be directly under the downspout. Mark the position of the two key holes in the grease trough top on the fan curbcap or on the roof curb depending on the desired location.

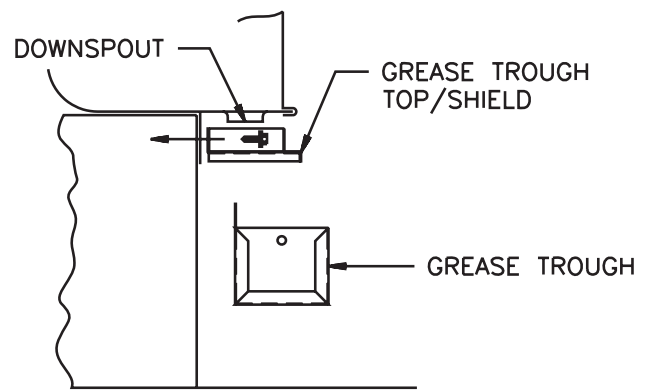

Figure A

2. Drill $\frac{5}{16}$ " (8 mm) holes at the locations marked on the curbcap or roof curb.
3. Thread the speed nut up to within $\frac{1}{4}$ " (6 mm) of the head of the $\frac{1}{4}$ - 20 x $\frac{3}{4}$ " round head machine screw and insert into the hole. Thread the standard $\frac{1}{4}$ " nut onto the screw on the inside of the curb and tighten.
4. Install the grease trough and its top on these two screws as shown in Figure B.

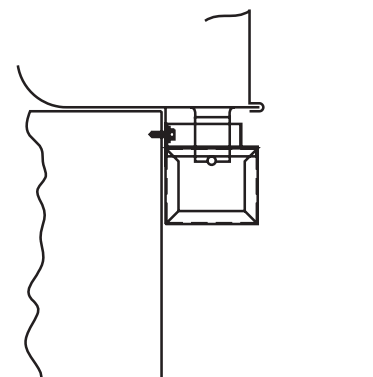

Figure B

GREASE TROUGH INSTALLATION (Wall Fan)

1. The grease trough should line up just below the windband lip as shown in Figure C. It should be centered below the fan when viewed from the outlet side of the fan.

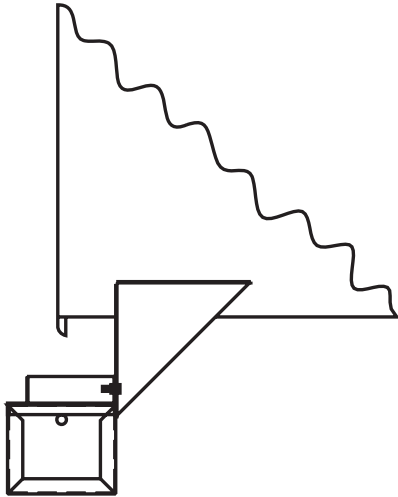

Figure C

2. Attach grease trough bracket supports to fan windband.
3. Attach grease trough bracket between supports using supplied bolts as shown in Figure D.

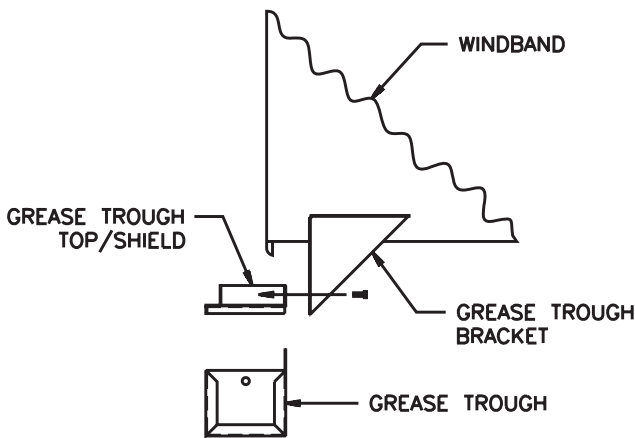

Figure D

4. Drill four (4) holes in the fan windband. Loosely assemble all parts. Position grease trough and mark holes of grease trough bracket. Mount to fan with supplied hardware.
5. Tighten two supplied 1/4" bolts into the grease trough bracket so that the grease trough and grease trough lid may be hung on the bolt heads.

GREASE TROUGH NOTE (Roof and Wall)

This grease trough has been designed with two chambers. One for collecting grease and the other for an escape channel for rain water. For proper

operation, the grease level must be kept above the bottom of the baffle plate which separates the chambers. If your operation produces a lot of grease, then **1 1/4" (32 mm) of water in the bottom of the grease trough should keep the grease from overflowing** until you clean the trough. If you are in an arid area and produce little grease, then 2" (51 mm) to 3" (76 mm) of water may be required.

Frequent inspections should be made of the grease trough until you can determine the level of water to be used and the frequency of cleaning. **To begin, fill the trough with 2" (51 mm) of water just before start up and check the trough the next morning.**

TYPE A - CURB HINGE INSTALLATION

1. Attach the pivot bolt to the fan curb and orifice section in the holes provided as shown in Figure E using one 5/16 x 1 1/4 inch bolt and nut per side. Place the bolt head to the outside.

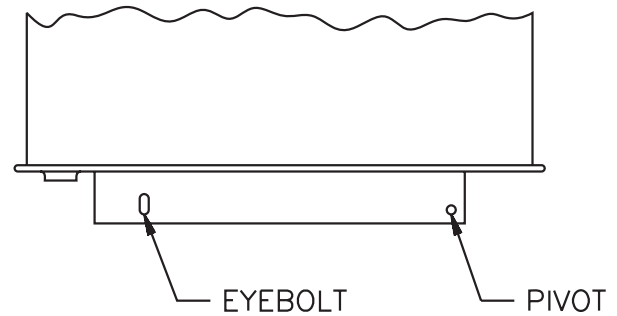

Figure E

2. With the fan mounted on the curb, position the hinge brackets on the curb as shown in Figure F and mark the holes.

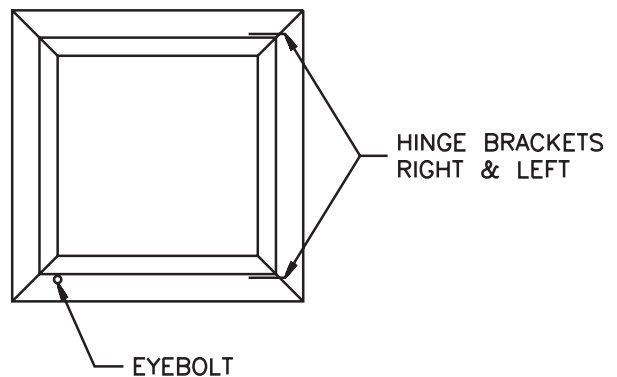

Figure F

3. Drill 1/4" (6 mm) holes at the location marked on the curb.
4. Attach the hinge brackets to the curb using 1/4 x 3/4 inch bolts and nuts provided. Place the bolt head to the outside. (Alternate method: 1/4" pop rivets may also be used.)

5. Install one eye bolt in the curb in the position shown in Figure F and Figure J. Use two nuts to capture the curb as shown in Figure G.

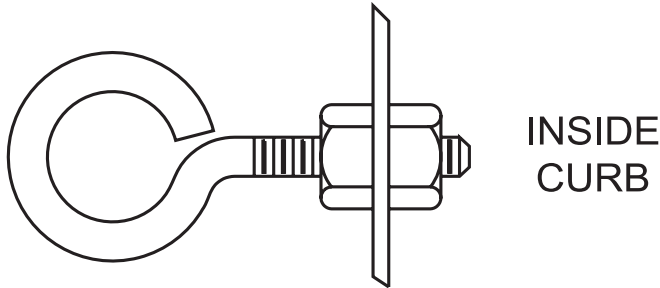

Figure G

6. Install another eyebolt in the curb and orifice section in the position shown in Figure E using two nuts as in Figure G. **Do not** extend the bolt more than one thread past the nut on the inside of the curb and orifice section.
7. The pivot bolts and lock nuts are attached to the fan curbcap only. The pivot brackets are attached to the roof curb only. No lock nut is needed on the pivot bolt to “back up” the pivot bracket. See Figure H.

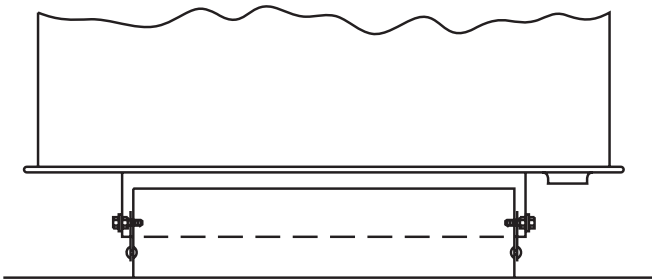

Figure H

8. Using the cable and connectors provided, connect the cable to the eyebolts so that the fan is supported after the fan is hinged as shown in Figure J.

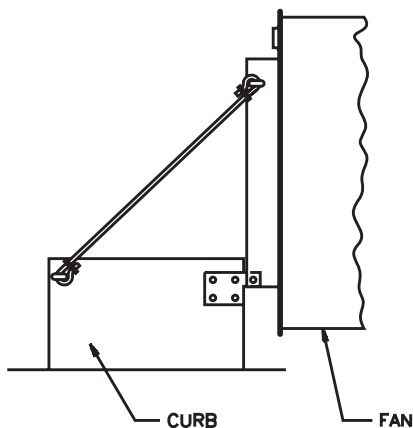

Figure J

TYPE B - CURB HINGE INSTALLATION

1. Attach hinge brackets to the fan curb cap as shown in Figure K using (3) 5/16 x 1" bolts and nuts per side. Place bolt heads to the inside of fan curb cap.

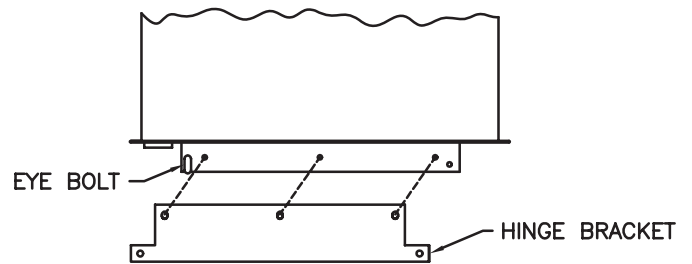

Figure K

2. Attach hinge bracket/fan assembly to roof curb base using (1) 5/16 x 1" bolt, bushing, and nut per side as shown in Figure M.

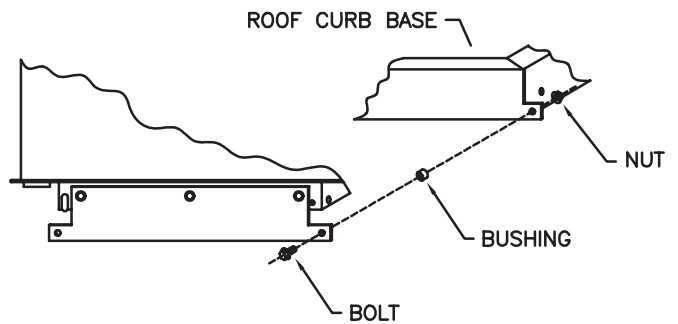

Figure M

3. Place the fan/roof curb base assembly onto roof curb.
4. Using hole pattern in roof curb base drill holes in roof curb. Bolt roof curb base to roof curb using (3) 5/16 x 1" bolts and nuts per side.
5. Install (1) eyebolt in the fan curb cap as shown in Figures J and K. Use (2) nuts to capture the fan curb cap as shown in Figure G.
6. Install the other eyebolt in the roof curb below the eyebolt in the fan curb cap as shown in Figure J. Use (2) nuts to capture the roof curb as shown in Figure G.
7. Using the cable and connectors provided, connect the cable to the eyebolts so that the fan is supported after the fan is hinged as shown in Figure J.

TERMS AND CONDITIONS OF SALE

ACCEPTANCE All orders and sales are subject to written approval and acceptance by an executive officer of the Company at Muskogee, Oklahoma, and are not binding on the Company until so approved.

DELIVERY All shipping and delivery dates are estimated only. No delays in delivery will subject the Company to any costs, damages or fees for late delivery. Delivery of the products herein specified shall be made F.O.B. point of shipment, unless otherwise stated. The Company shall not be liable for delay due to causes beyond its reasonable control, such as Acts of God, acts of the purchaser, acts of civil or military authorities, priorities, fires, strikes, floods, epidemics, war, riots, delays in transportation, car shortages, and inability, due to reasons beyond its reasonable control, to obtain necessary labor, material, or manufacturing facilities. In the event of such a delay, the date of delivery shall be extended for a period equal to the time lost by reason of the delay.

TERMS OF PAYMENT If, in the judgment of the Company, the financial condition of the purchaser at any time does not justify continuation of manufacture or shipment on the terms of payment specified, the Company may require full or partial payment in advance.

Pro rata payments shall become due as shipments are made. Each shipment or delivery shall constitute a separate sale, and the default of any shipment or delivery shall constitute a separate sale, and the default of any shipment or delivery shall not vitiate the contract as to other shipments or deliveries.

SALES AND SIMILAR TAXES The Company's prices do not include sales, use, excise, or similar taxes. Consequently, in addition to the price specified herein, the amount of any present or future sales, use, excise, or other similar tax applicable to the sale of the product herein shall be paid by the Purchaser, or in lieu thereof

the Purchaser shall provide the Company with a tax exemption certificate acceptable to the taxing authorities.

CANCELLATION Any contract resulting from the Purchaser's order may be canceled by the Purchaser only by negotiations and upon payments of reasonable cancellation charges which will take into account expenses already incurred and commitments made by the Company.

DESIGN CHANGES The Company reserves the right to make changes in design, improvements and additions in and to its products any time without imposing any liability or obligations to itself to apply or install the same in any product manufactured by it.

TITLE The title and right of possession of the products sold herein shall remain with the Company and such products shall remain personal property until all payments herein (including deferred payments whether evidenced by notes or otherwise) shall have been made in full in cash and the Purchaser agrees to do all acts necessary to perfect and maintain such right and title in the Company.

PRICE ADJUSTMENTS Prices are subject to change upon notice by the Company. Prices on existing orders are subject to surcharges in the event of cost increases of metals and transportation. All complete component accessory material manufactured by others and furnished with the Company's products such as motors, drives, vibration equipment, controls or other completely assembled component structures, are subject to adjustment to the price at time of shipment regardless of the date of original order entry.

SAFETY ACCESSORIES The Company manufactures products designed to serve multiple applications and offers a wide range of safety equipment, including guards and other devices, as may be required to meet

customer specifications. Without exception, the Company recommends that all orders include applicable safety devices. Products ordered without applicable safety devices is clearly the responsibility of the Purchaser. Further, the Purchaser warrants that it has determined and acquired any and all safety devices required for products sold by the Company. Weather covers and guards for motor and V-belt drives, couplings, shafts and bearings, along with inlet and outlet screens, are optional accessories noted in the price list.

GOVERNING LAW The rights, obligations and remedies of Purchaser and the Company, the interpretation of these terms and conditions and the sale of products by the Company shall be governed by Oklahoma law, without regard to any principles of conflict of laws.

ARBITRATION Any dispute arising under or in connection with these terms and conditions or the sale of products shall be settled by binding arbitration administered by the American Arbitration Association under its Commercial Arbitration Rules, and judgment on the award rendered by the arbitrator may be entered in any court having jurisdiction thereof. The dispute shall be resolved by one neutral arbitrator who shall have no affiliation with either Purchaser or the Company and shall be selected by the American Arbitration Association office in Dallas, Texas. The arbitration proceedings shall be held in Muskogee, Oklahoma.

APPLICABLE DOCUMENTS The agreement between the Company and the Purchaser relating to the products includes these terms and conditions of sale, any applicable installation and maintenance instructions provided by the Company and any terms appearing on the Company's quotation, sales order acknowledgment and invoice.

WARNING The Company products are designed and manufactured to provide reliable performance but they are not guaranteed to be 100% free of defects. Even reliable products will experience occasional failures and this possibility should be recognized by the Purchaser and all End Users. If these products are used in a life support ventilation system where failure could result in loss or injury, the Purchaser and all End Users should provide adequate back-up ventilation, supplementary natural ventilation or failure alarm system, or acknowledge willingness to accept the risk of such loss or injury.

WARNING DO NOT use in HAZARDOUS ENVIRONMENTS where fan's electrical system could provide ignition to combustible or flammable materials unless unit is specifically built for hazardous environments. Comply with all local and national safety codes including the National Electrical Code (NEC) and National Fire Protection Act (NFPA).

CAUTION Guards must be installed when fan is within reach of personnel or within eight (8) feet (2.5 m) of working level or when deemed advisable for safety.

DISCLAIMER The Company has made a diligent effort to illustrate and describe the products accurately in all Company literature; however such illustrations and descriptions are for the sole purpose of identification and do not express or imply any warranty.

LIMITED WARRANTY

WARRANTY AND DISCLAIMER: the Company extends this limited warranty to the original purchaser and warrants that products supplied by the Company, shall be free from original defects in workmanship and materials for two years from date of shipment (except for the warranty periods noted for products listed below), provided same have been properly handled, stored, installed, serviced, maintained and operated. This warranty shall not apply to products which have been altered or repaired without the Company's express authorization, or altered or repaired in any way so as, in the Company's judgment, to affect its performance or reliability, nor which have been improperly installed or subjected to misuse, negligence, or accident, or incorrectly used in combination with other substances. The Purchaser assumes all risks and liability for results of use of all products.

Evaporative cooling pads are warranted to be free of defects in materials and workmanship for a period of two years from date of shipment provided same have been properly handled, stored, installed, serviced, maintained and operated; and further, not subjected to excessive heat, corrosive agents or chemicals, or mechanical abuse that may cause tearing, crushing or undue deterioration, nor used on a system or in a manner other than that for which it was designed as explained in the product literature.

The following products are warranted to be free of defects in materials and workmanship for the periods shown from date of shipment: the Company's exclusive duplex split pillow block bearings and shaft five years, belts one year, Polyethylene tubing 90 days, AIR40 Heater warranty one year, AIR40 Emitter warranty three years and DDP fan lifetime warranty on its propeller, cone, and housing.

LIMITATION OF REMEDY AND DAMAGES: All claims under this warranty must be made in writing and delivered to P. O. Box 978, Muskogee, Oklahoma, 74402, within 15 days after discovery of the defect and prior to the expiration of two years from the date of shipment by the Company of the product claimed defective, and Purchaser shall be barred from any remedy if Purchaser fails to make such claim within such period.

Within 30 days after receipt of a timely claim, the Company shall have the option either to inspect the product while in Purchaser's possession or to request Purchaser to return the product to the Company at Pur-

chaser's expense for inspection by the Company. The Company shall replace, or at its option repair, free of charge, any product it determines to be defective, and it shall ship the repaired or replacement product to Purchaser F.O.B. point of shipment; provided, however, if circumstances are such as in the Company's judgment to prohibit repair or replacement to remedy the warranted defects, the Purchaser's sole and exclusive remedy shall be a refund to the Purchaser of any part of the invoice price, paid to the Company, for the defective product or part.

The Company is not responsible for the cost of removal of the defective product or part, damages due to removal, or any expenses incurred in shipping the product or part to or from the Company's plant, or the installation of the repaired or replaced product or part.

The warranties set forth above do not apply to any components, accessories, parts or attachments manufactured by other manufacturers; such being subject to the manufacturer's warranty, if any. To the extent not prohibited by the manufacturer's warranty, the Company shall pass through to Purchaser such manufacturer's warranty.

THE COMPANY'S WARRANTY IS IN LIEU OF ALL OTHER WARRANTIES, EXPRESS OR IMPLIED, ARISING BY LAW OR OTHERWISE, INCLUDING WITHOUT LIMITATION THE IMPLIED WARRANTIES OF MERCHANTABILITY AND FITNESS FOR A PARTICULAR PURPOSE, WHICH ARE HEREBY EXPRESSLY DISCLAIMED AND WAIVED. THIS WARRANTY CONSTITUTES THE COMPANY'S SOLE AND EXCLUSIVE WARRANTY FOR DEFECTIVE GOODS AND PURCHASER'S SOLE AND EXCLUSIVE REMEDY FOR DEFECTIVE PRODUCTS.

No employee, agent, dealer, or other person is authorized to give any warranties on behalf of the Company or to assume for the Company any other liability in connection with any of its products except in writing and signed by an officer of the Company.

REPLACEMENT PARTS If replacement parts are ordered, purchaser warrants that the original components in which these replacement parts will be placed are in satisfactory working condition, and when said replacement parts are installed, the resultant installation will operate in a safe manner, at speeds and temperatures for which the original product was purchased.

TECHNICAL ADVICE AND RECOMMENDATIONS, DISCLAIMER: Notwithstanding any past practice or dealings or any custom of the trade, sales shall not include the furnishing of technical advice or assistance or system design. Any such assistance shall be at the Company's sole option and may be subject to additional charge.

The Company assumes no obligation or liability on account of any recommendations, opinions or advice as to the choice, installation or use of products. Any such recommendations, opinions or advice are given and shall be accepted at Purchaser's and End User's risk and shall not constitute any warranty or guarantee of such products or their performance.

LIMITATION OF LIABILITY The cumulative liability of the Company to the Purchaser and any other persons for all claims in any way relating to or arising out of the products, including, but not limited to, any cause of action sounding in contract, tort, or strict liability, shall not exceed the total amount of the purchase price paid for those products which are the subject of any such claim. This limitation of liability is intended to apply without regard to whether other provisions of this agreement have been breached or have proven ineffective even if the Company has been advised of the possibility of such claims or demands. In no event shall the Company be liable to the Purchaser or any other person for any loss of profits or any incidental, special, exemplary, or consequential damages for any claims or demands brought by the Purchaser or such other persons.

INDEMNITY The Company's maximum liability to Purchaser and to any end user is as set forth above. The Company makes no warranty to anyone for any products not manufactured by the Company and shall have no liability for any use or installation of any products (whether manufactured by the Company or other manufacturers) not specifically authorized by this sale. Purchaser acknowledges various warnings by the Company regarding the products and its installation and use. If the Company incurs any claims, lawsuits, settlements, or expenses (including attorney fees) for any loss, injury, death or property damage including, but not limited to, claims arising out of the Purchaser's or any end user's installation or use of the products, the Purchaser shall indemnify and hold the Company harmless.